



भारत सरकार  
Government of India  
केन्द्रीय विद्युत प्राधिकरण  
Central Electricity Authority  
वितरण आयोजन एवं विकास प्रभाग  
Distribution Planning & Development Division  
[www.cea.nic.in](http://www.cea.nic.in)  
email [cedpdcea@yahoo.co.in](mailto:cedpdcea@yahoo.co.in)  
सेवा भवन, आर के पुरम, नई दिल्ली -110066  
Telefax :011-26102793/26197267 Ph 011-26732661

1.1



(आई एस ओ 9001-2008)

**No.505/6(low Cost meter)DPD/2011/**

**Dated 03 January, 2012**

**As per list (NGO etc)**

**Subject : Cost effective single phase Smart Meters – Comments on functional requirement specifications.**

Sir,

You may be aware that an India Smart Grid Task Force has been constituted under the Chairmanship of Shri Sam Pitroda, Advisor to Hon'ble Prime Minister of India on Public Information, Infrastructure & Innovations for systemic growth to evolve a road map for implementation of smart grid in India.

A Committee was constituted by MoP vide their letter No. 20/13/2009-APDRP dated 4-4-2011 under the chairmanship of undersigned comprising 17 members, from utilities, meters and chip manufacturers, to finalize the functional requirement specifications for cost effective single phase smart meters. The Committee has finalized functional requirement specifications for cost effective single phase meters so that integrated chip having communication module can be developed and a large scale roll out of meters is possible.

It is requested that your comments on the functional requirement specification uploaded on [www.cea.nic.in](http://www.cea.nic.in) and enclosed in the document may please be given at the earliest (**preferably by 20-1-2012**) so that further course of action be taken for design of the cost effective smart meters. Your comments may be sent on email of the undersigned i.e. [cedpdcea@yahoo.co.in](mailto:cedpdcea@yahoo.co.in) or [alokgupta53@yahoo.co.in](mailto:alokgupta53@yahoo.co.in) or [rajput.ashok@gmail.com](mailto:rajput.ashok@gmail.com)

Yours faithfully,

(आलोक गुप्ता)  
मुख्य अभियंता(डी.पी.डी)

**Encl: a/a**

**REPORT OF COMMITTEE**  
**ON**  
**COST EFFECTIVE AMI SOLUTION FRAMEWORK**

**2 Background:**

In pursuance to the decision taken in the meeting chaired by Shri Sam Pitroda, Advisor to Hon'ble Prime Minister of India on Public Information, Infrastructure & Innovations, on 30<sup>th</sup> March, 2011, regarding development of cost effective metering solutions which can suit Indian environment, a committee was formed by Ministry of Power vide their letter No 20/13/2009-APDRP dated 4<sup>th</sup> April 2011 comprising of following officers

- i. Shri Alok Gupta, Chief Engineer (DP&D), CEA.
- ii. Shri Kamesh Dave, CE, MGVCL, Gujarat
- iii. Shri PK Mitra, Addl. CE(Technology), WBSEDCL, Kolkata
- iv. Shri Rajesh Bansal, VP, BRPL, Delhi.
- v. Shri Suresh Chauhan, Executive Engineer, JdVVNL, Rajasthan
- vi. Smt Manju Gupta, Scientist 'E', BIS, Delhi.
- vii. Shri Sunil Singhvi, Chairman, IEEMA Metering Division
- viii. Shri C P Jain, M/S HPL Socomac Ltd
- ix. Shri Sanjay Ahuja, Senior DGM(Marketing), L&T
- x. Shri Anand Srivastava, Regional Manager, Landis + Gyr Ltd., Noida
- xi. Shri Vinod Tiwari, GM(Marketing), Genus Power Infrastructures Ltd. Jaipur
- xii. Shri Sandip Sinha, GM (Electricity), Itron India Pvt.Ltd.
- xiii. Shri Ganesh Guruswami, Free Scale Pvt Ltd
- xiv. Shri Milind Parab, CEO, Chipmunk Technologies Pvt. Ltd.
- xv. Shri Anil Sharma, A2Z Pvt limited, Gurgaon
- xvi. Shri J Pande, Director, IEEMA, Delhi.
- xvii. Shri A K Rajput, Director, CEA, Convener

The terms of reference of the committee are as under:

- Finalization of functional requirement/Specifications for cost-effective single phase electricity meters;
- Suggest changes in applicable Indian Standards(IS);
- Review of Central Electricity Authority's Regulations on Installation and Operation of Meters.

Two meetings of the committee were held (on 8<sup>th</sup> and 20<sup>th</sup> April 2011) to deliberate on above issues and to evolve a cost effective metering solution for single phase meters. Thereafter a meeting was taken by JS (D) ,MOP on 16.06.2011 to resolve the issues where divergent views were observed among committee members and other manufacturers.

### **3 Automated metering infrastructure (AMI) framework:**

- 3.1 Smart Grid technology named as one of the seven technologies that may help change the world, driven by governments and industry, is transforming how electricity is generated, stored, distributed, and consumed. It provides real-time monitoring of transformers and line voltage, data collection and remote control of system elements such as substations, intelligent devices, smart meters, power lines, capacitor banks, feeder switches, fault analyzers and other physical facilities. The smart Grid framework also provides consumer participation in Demand Side Management (DSM).
- 3.2 The USA Department of Energy's (DOE) Smart Grid Task Force defined the Smart Grid as a future power delivery grid that:
- Enables active participation by consumers
  - Accommodates all generation and storage options
  - Enables new products, services and markets
  - Provides power quality for the range of needs in a digital economy
  - Optimizes asset utilization and operating efficiency
  - Anticipates and responds to system disturbances in a self-healing manner
  - Operates resiliently against physical and cyber attacks, and natural disasters
- 3.3 AMI framework lays down the foundation for a two way communication between a meter and a central Head End System (HES).

AMI system is expected to support the broad feature as:

- i. Automated meter reading of the energy, load survey data, instantaneous parameters and event data from meter to Head End System (HES)
  - ii. Demand Response Facility to disconnect load on predefined variable load settings
  - iii. Remote configuration as well as remote firmware upgrade without affecting the metrology of the meter.
  - iv. Enable the consumer to read energy consumption, real time energy prices and control of load on an in home display and other Home Area Network (HAN) devices.
- 3.4 Two way communication between meter and Head End System can be achieved in following two ways
- i. Meter to HES directly over GSM/GPRS etc
  - ii. Meter to Data Concentrator Unit (DCU) over RF mesh/PLCC and from DCU to HES over GSM/GPRS etc

### **4 Communication Technology options**

#### **4.1 AMI Communication Infrastructure can be broadly divided into following:-**

- Local Area Network(LAN) /Neighborhood Area Network(NAN)/ Wide Area Network(WAN)
- Home Area Network(HAN)

4.2 Communication Technologies generally adopted are RF mesh/PLCC/GPRS/Wimax etc. a comparison of GSM/GPRS and RF mesh proposed to be adopted in India environment are given in **Annexure-I**.

4.3 **Proposed AMI Communication architecture**

AMI model that has a good chance of working out in the Indian Context would consists of four major components

- i. Smart Meter
- ii. LAN/WAN communication over RF mesh/PLCC/GPRS, Network Management System (NMS)
- iii. Home area network supporting in Home Display over Zigbee/PLC

The reading frequency proposed is once in 24 hours automatically. Alarms are to be communicated on their occurrences. On demand meter reading facility shall also be available.

4.3.1 **Meter to HES directly over GSM/GPRS:**

Areas where the meter population density is low should directly use WAN technology such as GPRS at meter end to directly send data to HES if economically feasible.

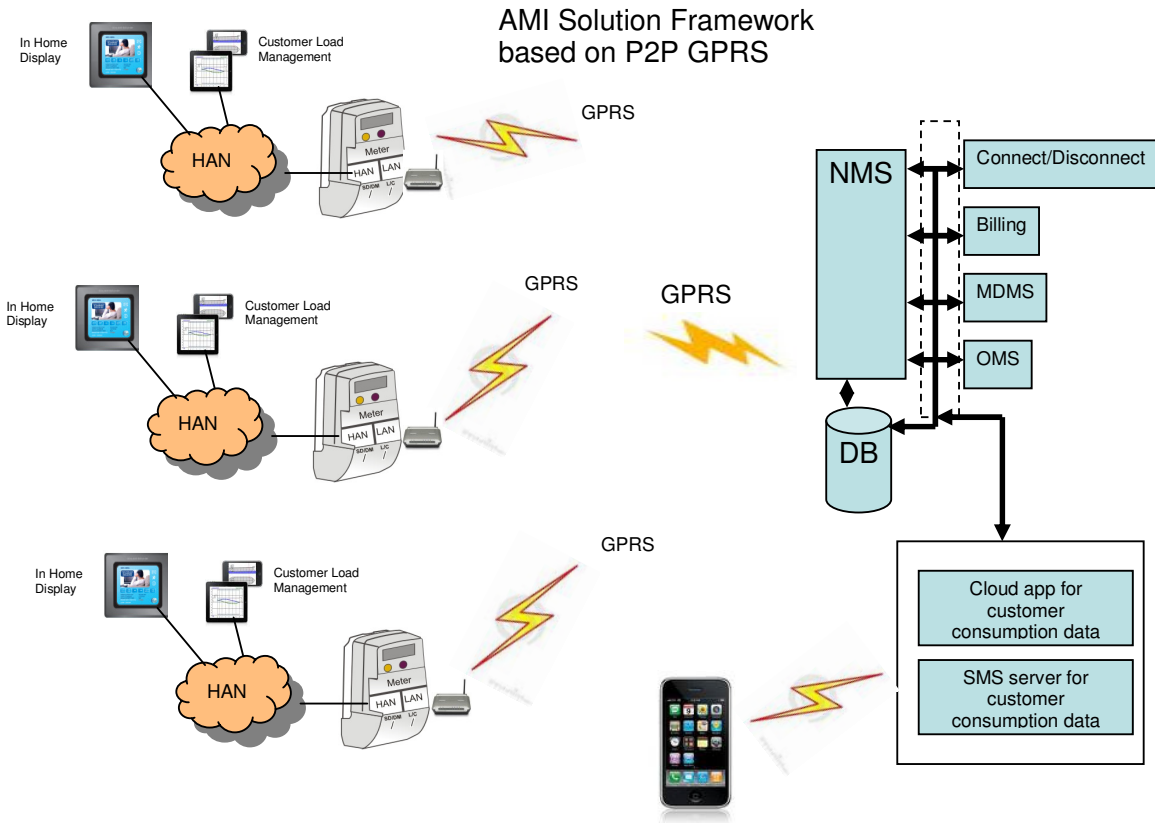

### 4.3.2 Meter to DCU over RF mesh/PLCC and from DCU to HES over GSM / GPRS etc

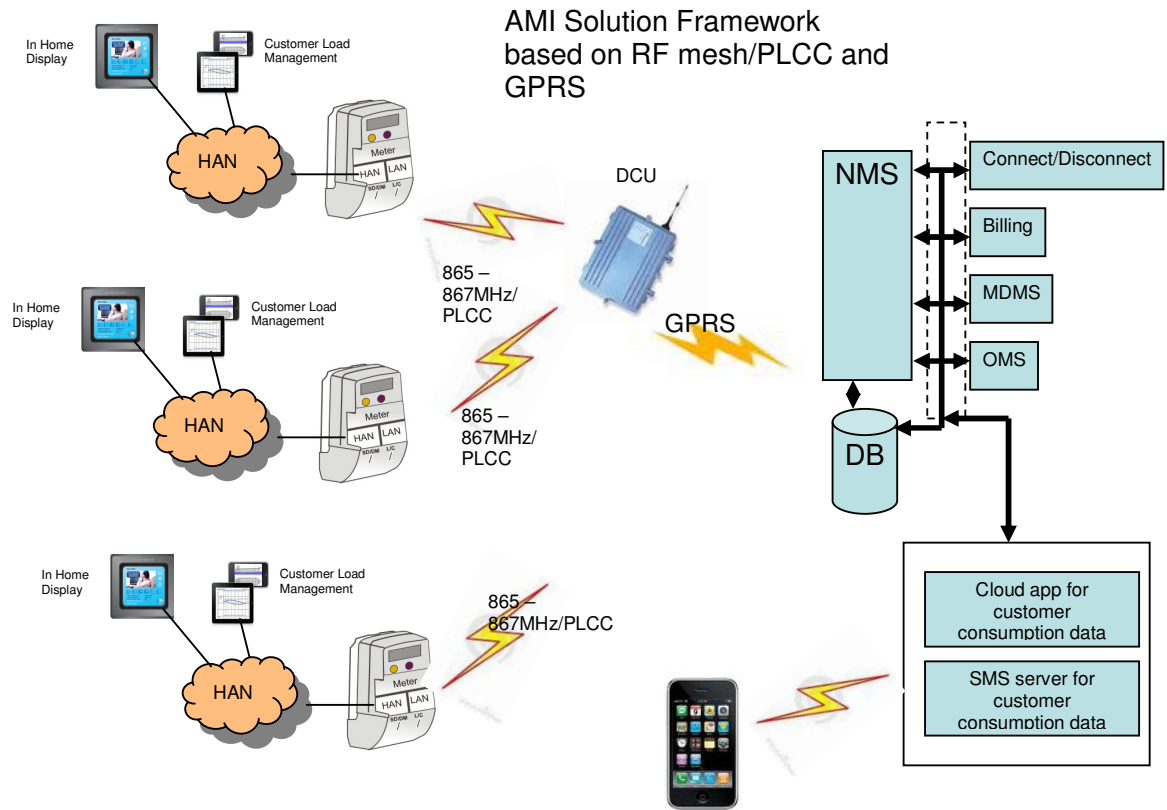

RF mesh/PLCC type of a network, especially in areas where the meter population density is high, may be a good choice. In such a scenario, a LAN/NAN would be formed using the RF mesh/PLCC that would feed data from multiple meters to a data concentrator unit (DCU) located on poles/DTs as the case may be. Data from DCU can be sent to HES using the WAN technology such as GPRS. It causes the system to be scalable and accommodates large numbers of meters in an AMI system. 865-867 MHz is the license free band as the power allowed is 1W in that frequency band and one can get better coverage. A 20 MHz band will be required to make the system futuristic. Any other de-licensed band which suits the application can also be utilized. RF mesh/PLCC can also be used for Home energy management depending upon the compatibility of devices. RF mesh has following advantages

- i. Obviate the difficulty of providing each meter an IP address.
- ii. Any meter can be added or removed in the existing network i.e dynamic addressing of meters.
- iii. Concentrator definition on field and requirement only on necessity
- iv. Dynamic Communication
- v. Auto-Registration
- vi. Self configuring / Self-Healing

PLCC is envisaged to be used in the high rise building.

*4.3.3 A pilot would be needed before large scale deployment of above technologies are implemented on large scale.*

#### **4.4 Home Area Network (HAN)**

Home area network (HAN) refers to the devices that a meter can communicate to in user's premises if compatible with the RF Mesh that is implemented in the meter. There are basically two technologies used on the HAN side i.e. Zigbee communication or PLC communication. RF is a wireless technology while PLCC is wired technology. In today's world of IT communication and considering the power quality level wireless technology would be a better choice. Both of the technologies find usage in different implementation scenarios.

## **5 Functional requirement of cost effective Single Phase Meter**

- 5.1 During the various meetings it was discussed that some of the facilities/features of conventional meter such as display, tamper , push button can be dispensed with in order to save the cost . During the discussions it emerged that removing the display may not be acceptable to consumer and would also not save money as the display are generally very cheap. Removing tamper features are also not advisable in Indian environment. However these can be mutually discussed by the Utility and AMI vendor during the implementation of AMI system after fixing up the options of communication technologies from point no.3 above. Regarding removing push buttons there were mixed reactions as such it is proposed to keep the push button to obviate the difficulty in reading by consumer in auto scroll mode and for implementing few of the Smart Meter Functionalities like Emergency Supply at higher tariff.
- 5.2 Smart meter for an AMI solution would support the regular features that a standard static meter and shall comply with the requirements of IS 13779. The connection/disconnection relay shall be as per IS15884. In addition it will support communication interface for data exchange between DCU /HES as the case may be as also interface for Home energy management including display.
- 5.3 The meter can have a GPRS modem in case when it connects to the NMS directly for spread out locations. In case of dense locations, meter shall have a RF mesh module working in the frequency band of 865-867 MHz that would communicate to a Data Concentrator Unit before the data is sent on WAN using GPRS. Any other de-licensed band which suits the application can also be utilized. RF module shall also be used for home energy management. PLCC can be used in High rise building areas.
- 5.4 HAN connectivity for conveying real time price, , load disconnect/connect within customer premises shall be over RF Mesh extension.
- 5.5 The reading frequency proposed is once in 24 hours automatically. Alarms are to be communicated on their occurrences. On demand meter reading facility shall also be available.

## 5.6 **Demand Response**

5.6.1 Cost effective solution is proposed to meet the following objectives :

- i. Automatic Meter reading for energy accounting and auditing, billing and collection
- ii. Demand response including above functions

5.6.2 Demand response in urban areas can be implemented in following manner:

- i. By informing consumer about the increase in tariff in grid constraint/increase of load in excess of predefined conditions
- ii. By disconnection of load within stipulated time in case of exceeding load/maximum demand
- iii. By disconnecting consumer power circuits in case two relays are provided (in case segregation of loads are resorted to by consumers like in Australia)
- iv. By disconnecting consumer appliances such as washing machines/air conditioners etc

5.6.3 The bi-directional communication shall be used for

- Communication to utility regarding actual load at the time of partial or full load disconnection.
- Disconnection of load based on advance agreement between utility and Consumer.
- Any other messages to display device

5.6.4 The switch (or multiple switches) can be mounted inside the meter.

## 5.7 **Group Metering:**

A group of meters can be housed and can be mounted on electric pole or any convenient location as being adopted by few states and countries like Brazil. In that case

5.7.1 All Meters are mounted on Pole and in house display device (IHDD) can be provided on consumer request.

5.7.2 All these meters shall be connected to Data Concentrator through RS-485 with upward link to HES via GPRS. .

- 5.7.3 Meter box shall be provided with at least IP-55 degree of protection.
- 5.8 Meter shall be provided with tamper detection and notification.
- 5.9 Power outage detection/restoration with information notification shall be provided in the meter.
- 5.10 Load profiling, Demand & Time of Use (TOU) calculation/ integral clock shall be provided in the meter.
- 5.11 Meters also can be designed based on OBIS codes/memory mapping wherever feasible else meter protocol may be called from manufacturer at the time of meter procurement depending upon utility's specific requirements.
- 5.12 Facility for remote meter configuration changes / remote firmware upgrade without affecting meter metrology.
- 5.13 Once RF mesh/PLCC radio communication is available HAN services can be built up to enable, the consumer to read energy consumption, real time energy prices and control of load in customer premises.
5. **In house display device (IHDD)** will play most vital role in smart meter. It is needed for consumer involvement, demand response and finally to accommodate/ interface with appliances. **In house display device** is not part of meter and is kept as optional and shall have minimum following features:

- i. Display of meter memory data with legends. Display content can be configurable.
- ii. On line real time communication with meters
- iii. Consumer friendly data presentation.
- iv. Tariff, supply cost related data, graphs.
- v. Consumption pattern
- vi. Display of power quality information
- vii. Display of utility broadcasted messages

Meter shall have facility to interface IHDD.

6. Utility shall provide the facility of furnishing bill related information on mobile phones as well.
7. **Cloud application for energy consumption data over GPRS/Internet:** Like an SMS server, a web based application can be implemented that can display energy consumption. The user logs in to the application using his username and password and can view the energy consumption information.
8. Keeping above in view Functional Requirement Specification for Cost effective Meter is given at **Annexure-II**.
9. **Suggestion for BIS**

BIS ET-13 may be suggested to review their entire suite of meter standards for changes if any. Some of the requirements are as follows:

- i. The scope of IS 13779 would be required to be reviewed and must cover smart meters.
- ii. Meter would be required to demonstrate the functionality of the relay. Relay must also comply with the proposed IS. A mention to this effect would be required to be incorporated in the appropriate IS.
- iii. Indian companion communication standard similar to that developed for HT and three phase CT operated meter incorporating all communication technologies would have to be developed by BIS.
- iv. Standard for group metering or amendment to existing standard may be made.
- v. IEEMA may take up this with BIS suitably.

10. **Suggestion for CEA Regulations on Installation and Operation of Meters**

CEA Regulations have been made very generic and only those requirements which are necessary from legal perspective as also minimum technical requirements have been covered. There is also provision of new technologies subject to approval of appropriate ERCs as such there is no change considered from the point of view of above requirement.

11. **Cost effectiveness of the solution**

These specifications have been drawn up based on the requirements of utilities and actual field conditions. Cost of the meter can be arrived at only after prototypes are made and pilots are carried out and will primarily depend on the following aspects in addition to many other factors:

- a) The final technology selected by the utility out of the multiple technologies mentioned for HAN & NAN,
- b) On the volumes (quantity)

12. Other communication technologies like Wimax are not considered in this document. The assurance on GPRS technology not getting obsolete for next 15 years will also be required as the system has significant GPRS communication components.

## Annexure-I

### Comparison of GSM/GPRS and RF Mesh communication

Sr no	GSM / GPRS	RF Mesh
1.	GSM / GPRS is essentially one to one communication. The maximum speed available is 9.6 kbps / 256 kbps but effective bandwidth available is only 2.4 kbps / 10 kbps.	Dedicated speeds of 100-250 kbps
2.	It shall be difficult to support the dynamic pricing in this case owing to the sequential delay of operation.	Built in broadcast and multicast commands for near simultaneous shutdown, load control and tariff management
3.	GPRS is mainly designed for data downloading (browser style information), where as meter data is mainly data uploading (meter to server). GPRS bandwidth reduces to 1/4 <sup>th</sup> on upload.	Upload and download speed is same.
4.	For provisioning dynamic IPs for so many meters linked to their SIM numbers, huge investment will be required for servers.	Since the requirement of dynamic IPs will be reduced by a factor of 5,000, simple low cost low power servers can manage.
5.	GSM / GPRS is highly unreliable in rural areas. Meters are permanently fixed devices – hence large no communication areas will be prevalent and may vary depending on power availability to mobile towers, especially in rural areas.	The advantages of RF reliability and low cost become more prominent in rural areas – India being essentially a rural economy. It offers no disadvantage in urban areas.
6.	GSM / GPRS connections are high susceptible to Digital Drop Out or call drop. Reconnection time is nearly 20 sec.	100% uptime.
7.	Real time connection and time synchronisation is impossible due to built in packet latencies.	Packet latencies are fixed and hence time can be synchronised accurately.

8.	The present revenue model of GSM / GPRS for telecom companies may not justify 10s of millions of SIM cards logged to the servers at all time. There may be a huge increase in running costs.	99.9% of the network is independent of telecom operators.
9.	Since the GSM / GPRS card is always in communicating mode, the power consumption is huge. It is more than 10 times of nearest comparable technology. A mobile phone actually balances between talk time and standby time, which is not the case with meters. For 200 million meters presently installed, the power requirement will go up by nearly 240 MW.	Negligible power requirement.
10.	To address the issue of tampering, the modem needs to be sealed inside the meter. If GPRS technology gets outdated (the case is most likely as it is very inefficient use of available bandwidth), all such meters will again have to be replaced.	The modem exists only on DCU, and can be easily replaced with upgraded technology.
11.	There is not even a single notable installation of GSM / GPRS AMR across the full spectrum of industrial / commercial / household and agricultural connections. It is still restricted to small quantities for industrial and large commercial establishments.	100s of thousands of RF meters getting installed in electric meters, gas meters and water meters worldwide every month.
12.	GPRS works in a scarce radio resource where voice takes precedence over data priority. With voice growing rapidly, the fate of reliable data in bandwidth hungry in mobile continues to remain uncertain unless data itself upgrades to 3G and 4G.	No limitation
13.	Fixed cost - Rs. 1200 per meter (cost of GPRS modem). Total budget – Rs. 24000 crore.	Fixed cost - Rs. 300 per meter (cost of RF modem). Total budget – Rs. 6000 crore.
14.	Running cost - Rs. 300 per month incurs an annual cost Rs. 72000 crores.)	Negligible in comparison – in fact the total investment cost in RF technology can be recovered in one month operating cost of GSM/GPRS. On DCUs the running cost will be less than 15

		crore.
15.	For Home Area Network – extra cost in RF module inside each meter.	Already provided
16.	The SIM card change on site is a huge cost if service provider is changed retaining the same number.	No such constraint

**Functional Requirement Specification  
for  
Single Phase Smart Meter**

(Reference Committee constituted vide Mop letter no: 20/13/2009-APDRP dated 4<sup>th</sup> April 2011)

<b>Particulars</b>	<b>Specification</b>
Applicable Standards	The meters shall comply to IS 13779 for all requirements except for those parameters which have been specifically mentioned to be otherwise in this specification.
Reference Voltage	240 V (-40% to +20%) Single Phase
Current Rating	5-30 A, 10-60A
Starting Current	0.2% of Ib
Accuracy	Class 1.0 as per IS 13779 for Active Energy
Operating Temperature range	-10 deg C to 55 deg C
Humidity	<= 95%
Frequency	50 Hz +/- 5%
Influence Quantities	As per IS 13779
Power Consumption of meter	As per IS 13779.
Meter Display	Min 6 digit LCD Display with legends to identify parameters on meter
Parameters to be measured	Instantaneous-V, I , kW, Power factor Cumulative – Active Energy, Apparent Energy Average power factor. Previous Month parameters : MD in kW, kWh, Average PF
Power Quality Information	Logging of quality of supply events like power on/off, over/under voltage, over current ( 50 events) Setting of Under/Over Voltage and Over current shall be decided by utility.
Maximum Demand	Should have Maximum Demand register kW with integration period 30 minutes. Resets should be auto-monthly or through communication command.
Load Survey/Interval Data	35 days data to be recorded with 30 minutes integration period for Active Energy, Average Voltage, Average Current. In addition cumulative mid night kWh (00.00 Hrs) shall also be recorded for 35 days.
Time of Use	Should support 4 tariff registers / 6 time zones per day.
LED / LCD Indicators	LED indicator for pulse/kWh. LED / LCD Indicator for Tamper, Disconnection, Earth leakage.
Tamper/Event recording	A total of last 50 events considering all tampers defined must be detected and logged as tamper events on first in first out basis along with date & time of occurrence and restoration, total tamper counts with tamper identification. Snapshot of kWh, V and I shall be recorded along with the

	following tamper events.
	Cover open detection – First instance
	Neutral disturbance
	Magnetic Interference
Alarm	Alarm for power on/off, Under Voltage, Over Voltage, Over Current, Mal functioning of relay, malfunctioning of diagnostic events shall be generated and communicated to the HES immediately.
Measuring Elements	Meter should have two measuring elements - one in phase and other in neutral path.
Anti-Tamper features	As per CEA Regulations.
Load Control	<p>Relay for connection/disconnection</p> <p>Phase and Neutral Disconnection on the following conditions:</p> <ul style="list-style-type: none"> <li>i) Over current</li> <li>ii) Load Control Limit</li> <li>iii) Pre-programmed Tamper conditions</li> <li>iv) Disconnect signal from Utility Control Centre such as balance unavailable in case pre-paid facility is availed by consumer.</li> </ul> <p>Load Control limits shall be programmable.</p> <p>The disconnection mechanism is as follows:</p> <ul style="list-style-type: none"> <li>i) The switch re-connection shall be decided by meter locally. It will try to re-connect the load up to 3 times, with 5 minutes interval.</li> <li>ii) if the consumption is still more than the programmed limits, it will lock out and wait for 30 minutes (lock out period).</li> <li>iii) if the consumption is still above the limit , the procedure as defined above in i) and ii) shall be repeated.</li> </ul> <p><b>Reconnection mechanism:</b> Reconnection shall normally be done from HES. In case of failure of communication/HES, reconnection shall be possible through HHU locally and the same shall be password protected.</p>
Connect/Disconnect Indication	<p>Connect/Disconnect facility to be provided on both the wires i.e. phase and neutral simultaneously.</p> <p>Status of Relay – indication of status of relay i.e. Connected / Disconnected should be available on display as well as through communication.</p> <p>Connection and Disconnection should also be logged as events.</p>
Programmability	It should be possible to program the parameters limits / values from remote through sufficiently adequate security mechanism. Once programmed it will be possible for the programmed parameters to come into effect from a certain date & time. Meteorology under such condition must remain intact and shall not be upgradable from remote.
Communication	Optical / Rs 232/RS 485 will be provided for local communication. In addition to this the meter will have a provision for a built in Communication Module for NAN (Neighborhood Area Network) i.e. from Meter to Data Concentrator or directly for WAN (Wide Area Network). This

	Communication Module could operate on Low Power Radio / RF with Mesh/PLC/GPRS (directly up to HES). The communication module option can be decided at the time of actual implementation by the utilities. Number of ports for external interfaces shall not exceed two.
Communication Protocol	The present IS 15959 is not applicable for single phase meters which would be developed by BIS committee. Meanwhile, Meter manufacturers will share their protocol and memory map with the Utility.
RTC & time synchronization	Meter shall have RTC with 20 years calendar programmed in the memory and provision for time synchronization.
Data Retention	Non Volatile Memory (non battery backed up) with 10 years data retention in absence of power.
Meter Housing	High grade engineering plastic, IP51, provision for sealing meter cover to meter base, provision for sealing terminal cover, provision for sealing any other compartment for communication module.
Data display facility (manual/Auto)	Data Display shall have following three modes: <ol style="list-style-type: none"> <li>1. Auto Scroll</li> <li>2. Scroll with Push-button</li> <li>3. High Resolution (Shall display energy values with resolution of 2 digits before decimal and 4 digits after decimal.</li> </ol>
In House Display device (Optional)	6 Digit LCD Display with Legends to identify parameters. Display will be mounted inside house. Communication with meter may be wired or wireless. Display should show the readings appearing on meter. IHDD shall display the tariff details, bill in Indian rupees & due date of payment bill/tariff related information as sent from data centre for demand response. It should also be capable of showing Alphanumeric text message from utility. In case meters are installed inside houses the size of the meter display can be sufficiently increased to accommodate the complete details in addition to the existing information of utilities like - Tariff details, bill in Indian Rupees, the due date of payment etc.
HAN (Home Automation Network)	The meter communication module shall include HAN capability to support IHDD.
Reading frequency	The reading frequency proposed is once in 24 hours automatically. Alarms are to be communicated on their occurrences. On demand meter reading facility shall also be available.
Guarantee	Meter should be guaranteed against defects arising out of faulty design or workmanship for a period of five and a half years from the date of receipt of consignment or 5 years from the date of commissioning, whichever is earlier.